

Instruction Sheet - Multi-Height Endura Video Tables

Endura Models LE-DUO and LEL-DUO

Congratulations for having chosen an excellent Luxor product.

Your purchase is backed by Luxor's satisfaction guarantee. Luxor is a service oriented company. As a service to you, we are enclosing a "satisfaction guaranteed" request card. Should a problem arise needing our assistance simply fill out the card and fax it to us toll-free or mail postage paid to Luxor. Be sure to include your telephone

number. Upon receipt of your service request, we will give it immediate attention to be sure that you will be completely satisfied with your purchase.

Thank you for your confidence.

Customer Service Dept
LUXOR
2245 Delany Road
Waukegan, IL 60087



26 High Model



34 High Model

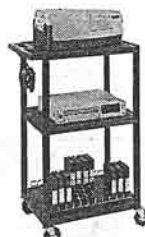

42 High Model

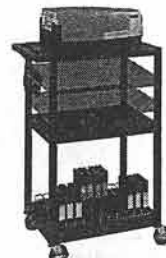

LEL-DUO

PARTS LIST

Model LE-DUO

- 1 - Endura shelf w/ casters sockets
- 1 - Endura shelf w/ handle
- 1 - Endura shelf w/ eight leg posts
- 4 - 6 1/4" tubular legs
- 4 - 14 1/4" tubular legs
- 4 - 17 3/4" tubular legs
- 4 - Casters (2 w/brake)
- 1 - Grommet pass through
- 1 - Plug housing cover
- 2 - Sheet metal screws

Tools Required:

- 1 - Rubber Mallet
- 1 - Slotted Screwdriver

Model LEL-DUO

- 1 - Endura shelf w/ casters sockets
- 1 - Endura shelf w/ handle
- 1 - Endura shelf w/ eight leg posts
- 4 - 11" tubular legs
- 4 - 17 1/2" tubular legs
- 4 - 19" tubular legs
- 4 - 25" tubular legs
- 4 - Casters (2 w/brake)
- 1 - Grommet pass through
- 1 - Plug housing cover
- 2 - Sheet metal screws

IMPORTANT:

The electric unit should be assembled first. See reverse side. If your Endura table does not have the Electrical Assembly and Cable Track™ Cord Management System start by closing the electric plug housing in the handle of the top shelf as illustrated below.

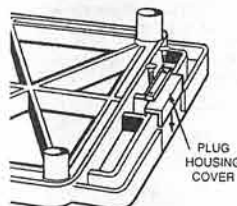

WARRANTY

The Luxor Lifetime Warranty:
Luxor Endura Tables are fully warranted when used for their intended purposes. Use for other purposes, wherein weight loads become excessive, will negate the warranty and may create a safety hazard.

LE-DUO

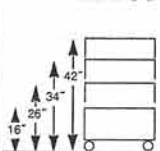

LEL-DUO

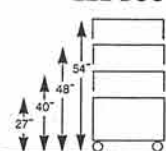

LE-DUO and LEL-DUO multi-height Endura tables enable you to assemble four different heights in one table. LE-DUO 16" and 26" table and LEL-DUO 27" and 40" table have two shelves. LE-DUO 34" and 42" table and LEL-DUO 48" and 54" table have three shelves.

LE-DUO 16" & 26" Height LEL-DUO 27" and 40" Height

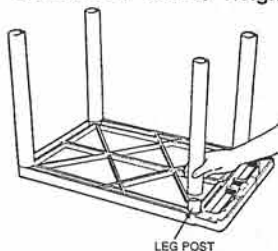

- 1 Lay top shelf (with handle) ribbed side up on a smooth surface. Push all 4 legs onto leg posts.

16" Table use 6 1/4" legs.
26" Table use 17 3/4" legs.
27" Table use 17 1/2" legs.
40" Table use 25" legs.

2

Position bottom shelf, ribbed side up, over the 4 legs and insert leg posts into legs. Using a rubber mallet, firmly hammer bottom shelf into legs until all 4 legs are seated (flush) against the surfaces of both shelves.

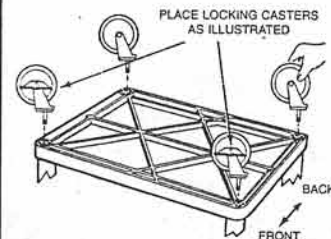
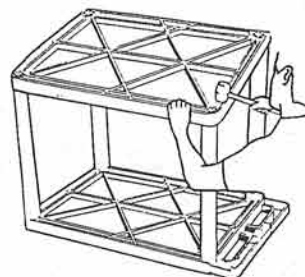

3

Push the four casters firmly into the holes in each corner of the bottom shelf. Important: Casters must be fully seated. Tap firmly with rubber mallet to properly seat casters. Turn your Endura table right side up.

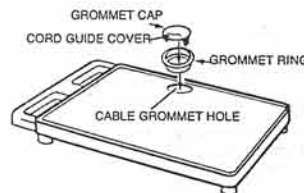

4

Install grommet ring by tapping into place with rubber mallet. Insert grommet cap as illustrated. For tables with electric assembly, snap off cord guide cover from grommet cap so equipment plug may be run through grommet to plug unit, then insert grommet cap into grommet ring. Your Endura Mobile Table is now ready for use.

LE-DUO 34" & 42" Height LEL-DUO 48" and 54" Height

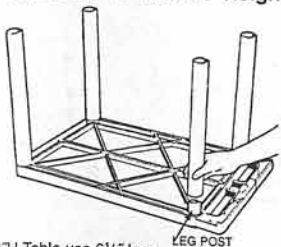

14" Table use 6 1/4" legs.
27" Table use 14 1/4" legs.
18" Table use 11" legs.
14" Table use 25" legs.

- 1 Lay top shelf (with handle) ribbed side up on a smooth surface. Push all 4 legs onto leg posts.

2

Position center shelf (with 8 leg posts) ribbed side up, over the 4 legs and insert leg posts into legs. Using a rubber mallet, firmly hammer center shelf into legs until all 4 legs are seated (flush) against the surfaces of both shelves.

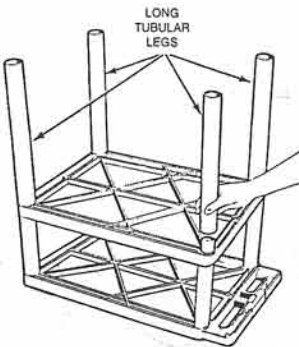
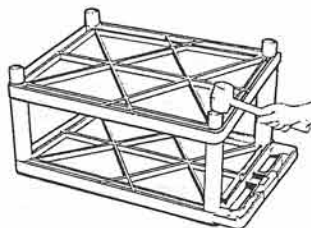

- 3 Push remaining 4 legs into leg posts of center shelf.

4

Position bottom shelf, ribbed side up, over the 4 remaining legs and insert leg posts into legs. Using a rubber mallet, firmly hammer bottom shelf into legs until all 4 legs are seated (flush) against the surfaces of both shelves.

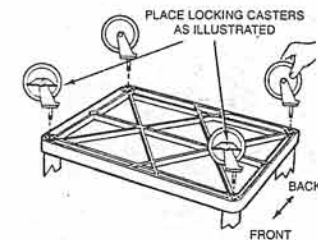
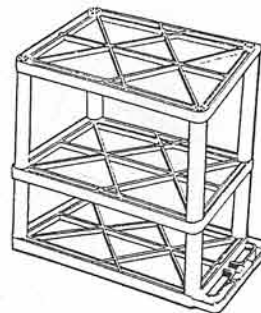

5

Push the four casters firmly into the holes in each corner of the bottom shelf. Important: Casters must be fully seated. Tap firmly with rubber mallet to properly seat casters. Turn your LP table right side up. It is now ready for use.

6

Install grommet ring by tapping into place with rubber mallet. Insert grommet cap as illustrated. For tables with electric assembly, snap off cord guide cover from grommet cap so equipment plug may be run through grommet to plug unit, then insert grommet cap into grommet ring. Your Endura Mobile Table is now ready for use.

Instructions For - Electrical Assembly Cable-Track™ Management System and Cord Wrap

Your Endura mobile equipment table incorporates the Cable-Track™ Cord Management System. This exclusive feature manages electrical cords, keeping them safely out of the way. This system includes a 3-outlet, 15 foot surge suppressing electric assembly, UL and CSA listed, which is built into the safety handle. Please review these instructions carefully to maximize the added safety provided by Luxor's Cable-Track™ Cord Management System.

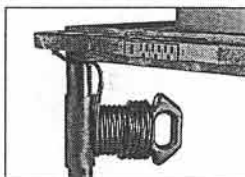

PARTS LIST

- | | |
|--------------------------------|------------------------------|
| 1 - Surge protected power cord | 1 - Power cord retainer clip |
| 1 - Cord wrap | 2 - "E"-clips |
| 3 - Cord management ties | 3 - Cord management clips |
| 4 - Sheet metal screws | |

ILLUSTRATION #A

IMPORTANT

1 The electrical unit should be assembled first.

Cord wrap must be installed on leg before assembly of complete unit. See illustration #B.

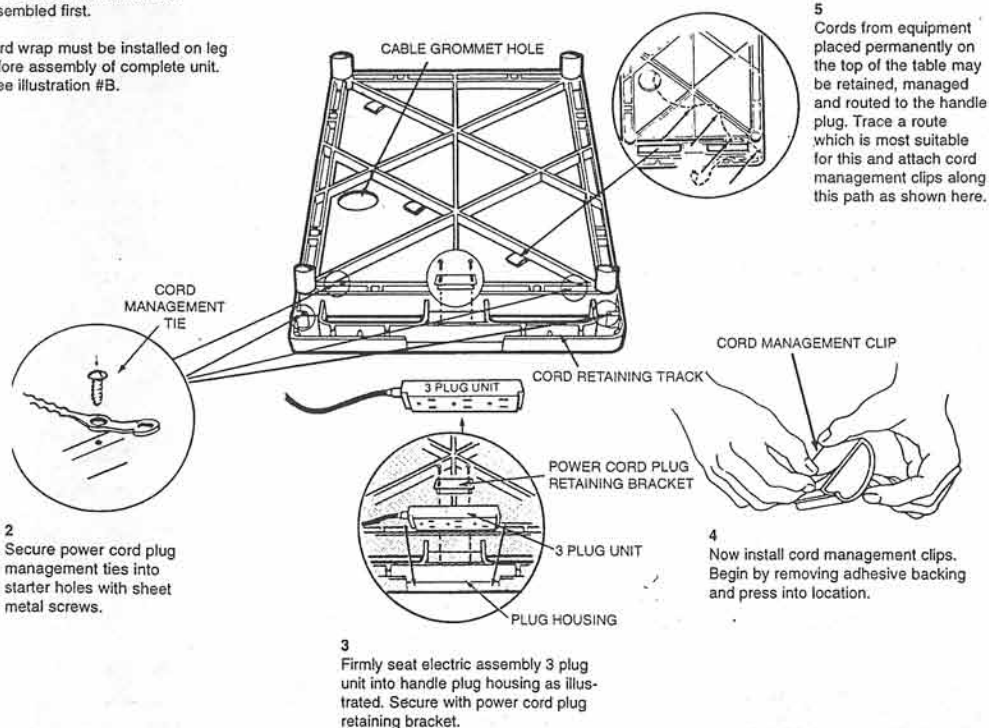

ILLUSTRATION #B

* Install correct size leg on top shelf then slide cord wrap down over leg into position.

6 Thread power cord through cord retaining track, secure with cord management ties by wrapping tie around cord and fastening. Cut off any unnecessary extra length of tie. Wrap remaining cord around the cord wrap bracket. For safety and neat appearance, secure cord plug to cord by utilizing plug snap.

