

# INSTRUCTION SHEET - Endura Mobile Cabinet Tables

## Models LEF-34C, LEF-40C, LEF-42C AND LEF-56C



Customer Service Dept  
2245 Delany Rd  
Waukegan, IL 60087  
Ph: 847/244-1800 • 800/323-4656  
Fax: 847/244-1818 • 800/327-1698



LEF-34C



LEF-56C

## PARTS LIST

- 1 - Top Shelf w/handle
- 4 - Tubular Legs
- 1 - Bottom Shelf
- 2 - Cabinet Side Panels
- 1 - Back Panel
- 1 - Door in Frame
- 4 - Casters ( 2 w/brake)
- 1 - Grommet Cap
- 1 - Cord Guide Cover
- 1 - Grommet Rings
- 1 - Large "U" Bracket
- 1 - Cord Wrap Bracket
- 2 - Machine Screws
- 2 - Small Kep Nuts
- 1 - Rubber Band

- TOOLS REQUIRED:**
- 1 - Rubber mallet
  - 1 - Slotted screwdriver
  - 1 - 7/16" wrench

Start by closing the electric plug housing in the handle of the top shelf as illustrated.

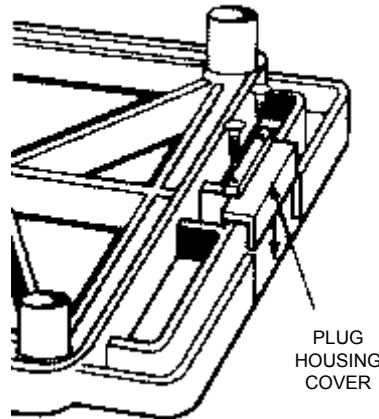

PLUG HOUSING COVER

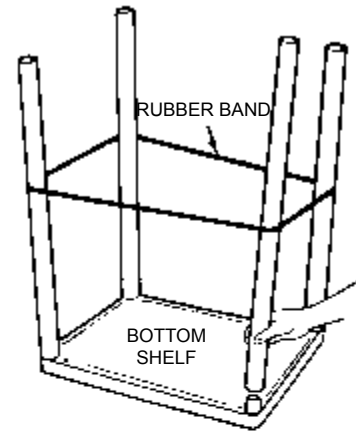

- 1.** With bottom shelf facing up push all four legs onto corner posts. Using rubber mallet hammer legs firmly into position. Legs must be seated (flush) against the shelf surface. Place rubber band around legs to aid in the assembly of side panels and doors.

MAKE SURE STUD WELDS ARE CLOSER TO BOTTOM THAN TOP.

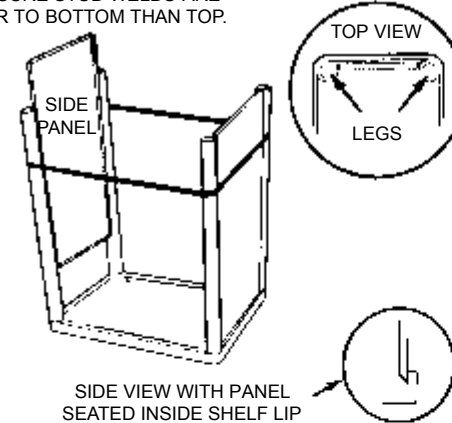

- 2.** Install the side panels first. Slide panels down between legs until they are nested inside the shelf lip and flush against the shelf surface. Rubber band will hold legs and side panels in place while installing back panel and front door.

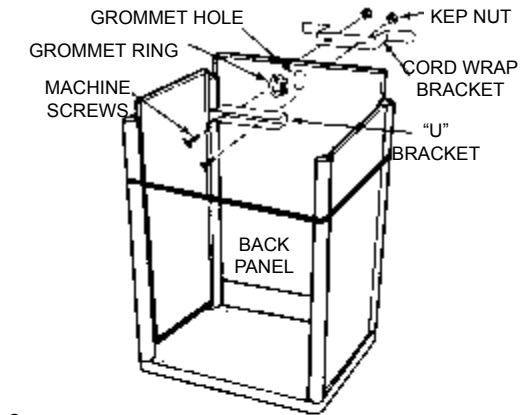

- 3.** Install the back panel in the same manner as side panels. Install grommet ring into grommet hole. Insert two machine screws as illustrated through "U" bracket into back panel and through slots in cord wrap bracket. Align the cord wrap bracket onto machine screws from the outside of back shelf and secure with two kep nuts.

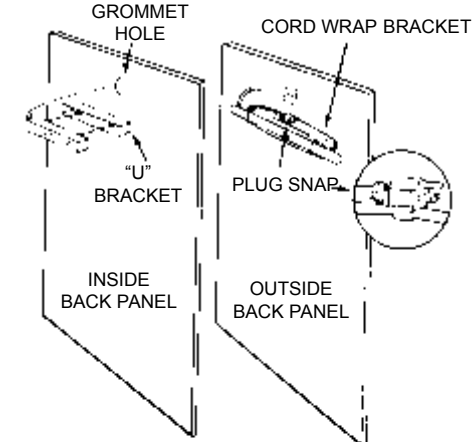

- 4.** Press 3-outlet power cord into "U" bracket and feed remaining cord through grommet hole and wrap remaining cord around cord wrap bracket. For safety and neat appearance, secure cord plug to cord with plug snap.

**NOTE: MODELS LEF-40C AND LEF-56C HAVE DOUBLE DOORS**

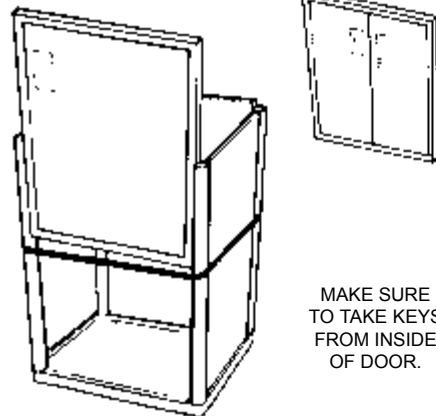

- 5.** Install door panel same as back panel with door handle at top. Be sure door opens outward and door frame is also placed between legs and nested flush on the shelf floor.

MAKE SURE TO TAKE KEYS FROM INSIDE OF DOOR.

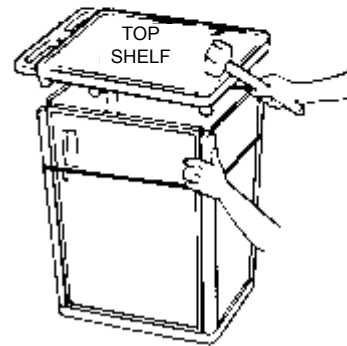

- 6.** Begin seating of top shelf by holding door panel, leg and side panel as illustrated. Gently tap corner posts into legs until all posts are partially inserted into legs. Repeat hammering action more firmly going around to each corner, being certain that each panel nests inside the lip of the top shelf. Repeat this action until top shelf is fully nested.

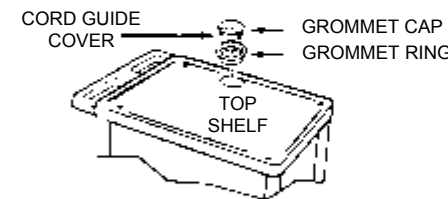

- 7.** Install grommet ring and grommet cap into top shelf. For tables with electric assembly, snap off cord guide cover from grommet cap to allow equipment plug entry. Insert grommet cap into grommet ring.

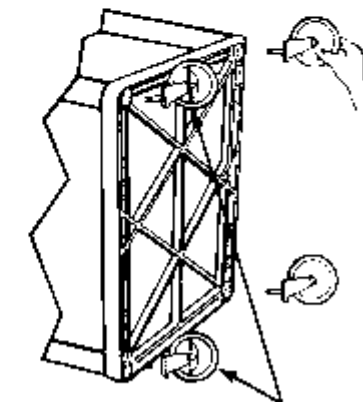

PLACE LOCKING CASTERS AS ILLUSTRATED

- 8.** Push the four casters firmly into the holes in each corner of the bottom shelf. **Important:** casters must be fully seated. Tap firmly with rubber mallet to properly seat casters. Turn your Endura Table right side up.

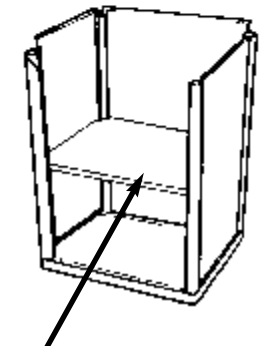

- 9.** Open door and insert extra shelf onto the shelf supports on the side panels.