

# MB7240LB MOBILE MAGNETIC GHOST GRID WHITEBOARD

## Product Specifications

Item Number	MB7240LB
Material	Painted Steel
Frame	Aluminum; 1" edging
Surface Material	Magnetic Painted Steel
Grid Pattern	2" x 2"
Whiteboard Tape	Ships with 2 rolls
Full Dimensions	74.5"W x 23"D x 69"H
Board Dimensions	72"W x 40"H
Base Dimensions	74.5"W x 23"D
Tray Style	Full Length
Casters (4)	2" casters; two with locking brakes
Actual Weight	41 lbs.
Shipping Method	Freight
Shipping Carton Dimensions	77"W x 49"D x 2"H
Shipping Weight	59 lbs.
Assembly Required	Yes

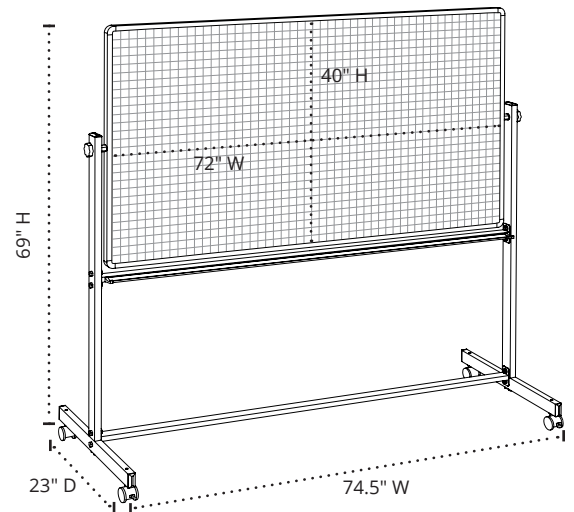
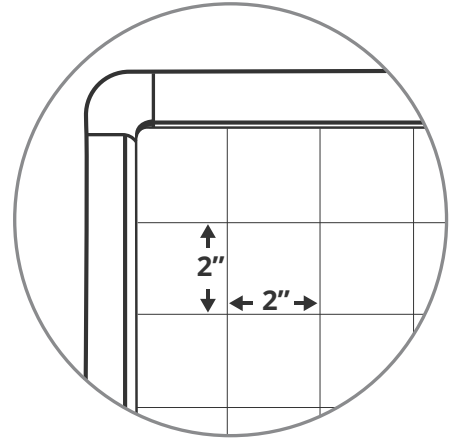

To Order, Call Your  
Sales Representative  
or 800-323-4656