

### PARTS KEY:

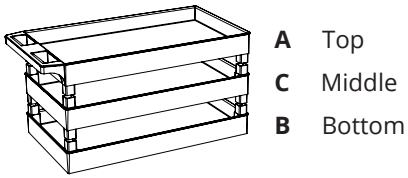

Tub Shelves\*  
(SEC, EC, STC, and TC models)

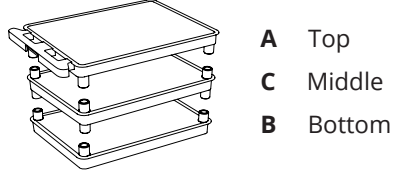

Flat Shelves\*  
(BC, HE, HC, LE, LP, and WT models)

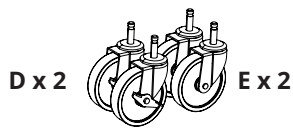

4" Standard Casters  
(All models except for ECHD and XLC)

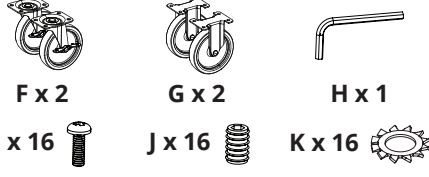

5" Heavy-Duty Casters + Hardware  
(ECHD and XLC models)

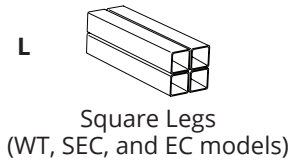

Square Legs  
(WT, SEC, and EC models)



Round Legs  
(LE, LP, STC, TC, and BC models)

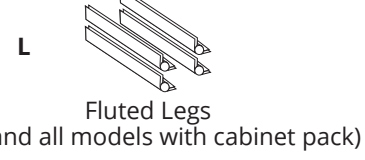

Fluted Legs  
(XLC and all models with cabinet pack)

### REQUIRED TOOLS:

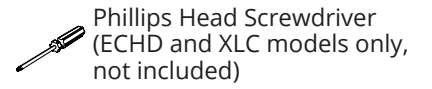
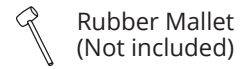

### IMPORTANT:

If your cart includes options such as a power strip, pullout shelf, locking drawer, or locking cabinet, installation instructions for those components will be included in their packaging.

### \*NOTE:

Some BC, STC, and TC models come with a mix of flat and tub shelves.

### OPTIONAL ACCESSORIES:

(If your cart includes one or more of the optional accessories shown below, separate installation instructions are enclosed with each accessory.)

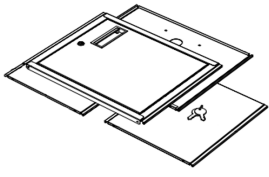

Cabinet Pack

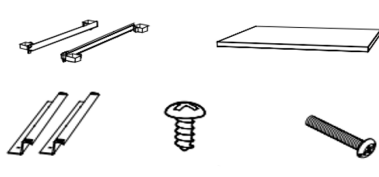

Pullout Shelf + Hardware

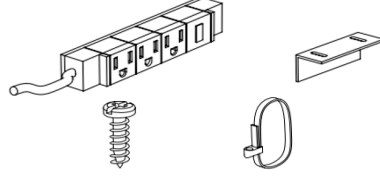

3-Outlet Power Strip + Hardware

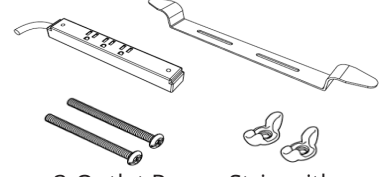

3-Outlet Power Strip with  
Cord Wrap + Hardware

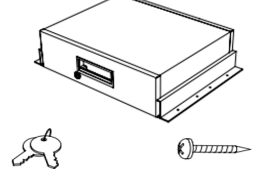

Locking Drawer + Hardware

### WHAT'S IN THE BOX:

Part	Standard 2-Shelf	Standard 3-Shelf	Standard 4-Shelf	Standard 5-Shelf	Standard 6-Shelf	Heavy-Duty 2-Shelf	Heavy Duty 3-Shelf
Top Shelf (A)	1	1	1	1	1	1	1
Bottom Shelf (B)	1	1	1	1	1	1	1
Middle Shelf (C)	0	1	2	3	4	0	1
Locking 4" Caster (D)	2	2	2	2	2	0	0
Non-Locking 4" Caster (E)	2	2	2	2	2	0	0
Locking 5" HD Caster (F)	0	0	0	0	0	2	2
Non-Locking 5" HD Caster (G)	0	0	0	0	0	2	2
Allen Wrench (H)	0	0	0	0	0	1	1
Threaded Insert (I)	0	0	0	0	0	16	16
Threaded Screw (J)	0	0	0	0	0	16	16
Star Washer (K)	0	0	0	0	0	16	16
Legs (L)	4	8	12	16	20	4	8

### ASSEMBLY INSTRUCTIONS:

#### Standard Models

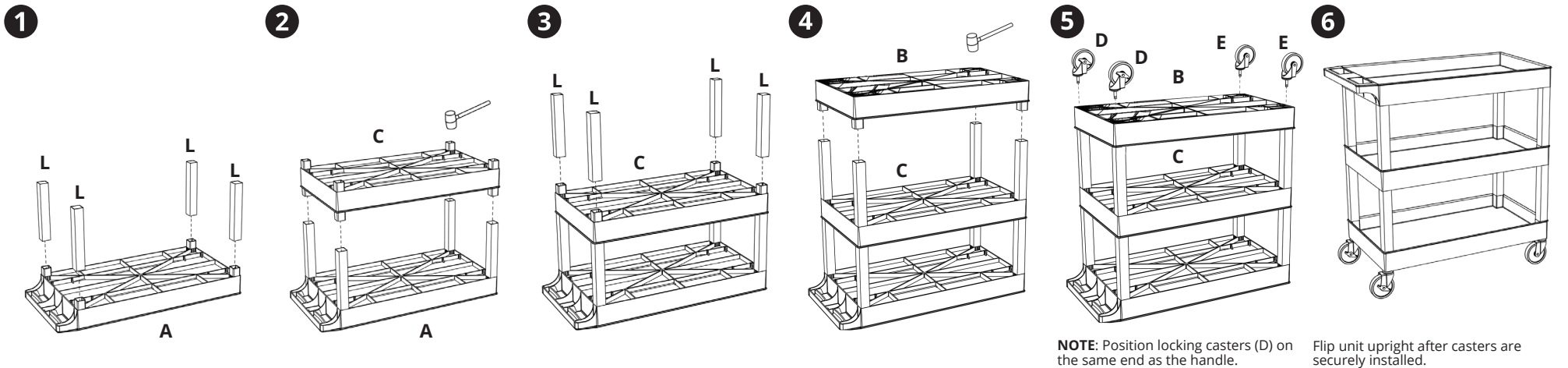

NOTE: Position locking casters (D) on the same end as the handle.

Flip unit upright after casters are securely installed.

#### Heavy-Duty Models

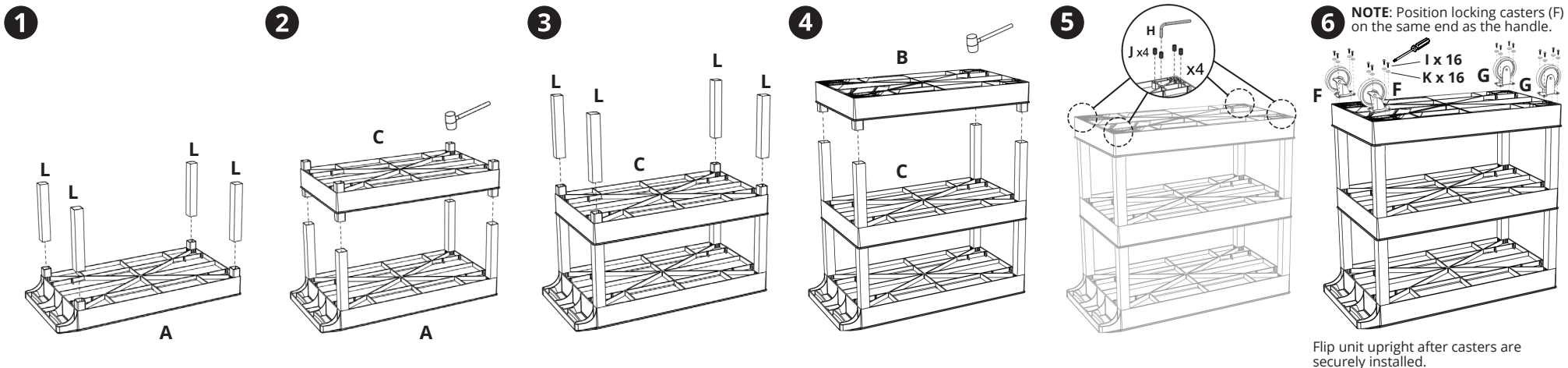

NOTE: Position locking casters (F) on the same end as the handle.

Flip unit upright after casters are securely installed.

#### Cabinet Pack Models

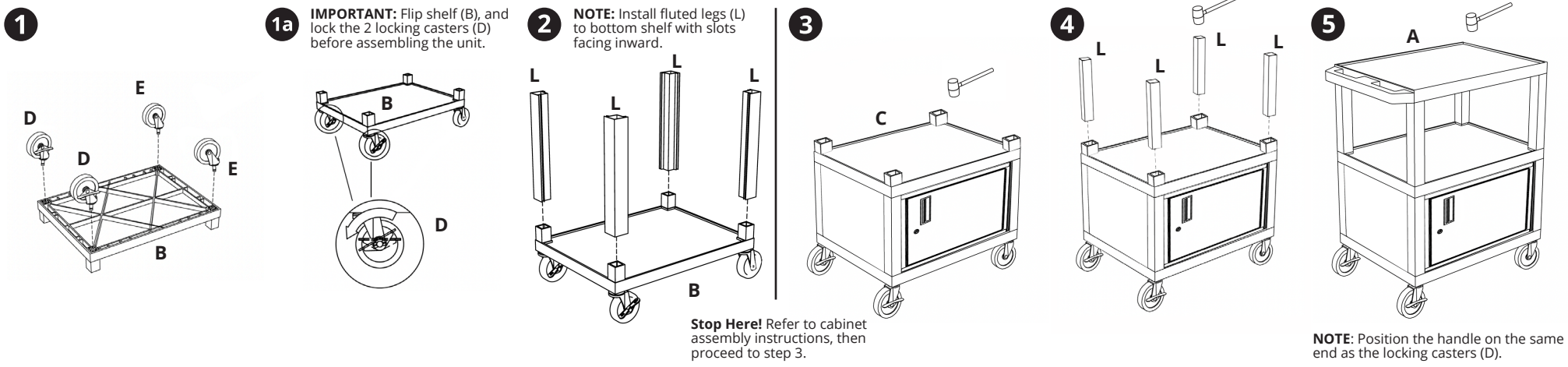

Stop Here! Refer to cabinet assembly instructions, then proceed to step 3.

NOTE: Position the handle on the same end as the locking casters (D).

Tuffy Cart

### Parts List

### Tools Required

- Phillips Screwdriver

**G** x1

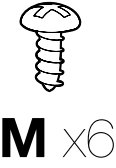
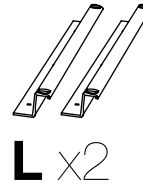
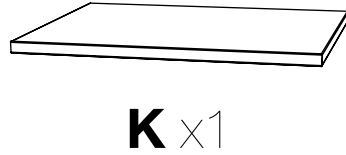
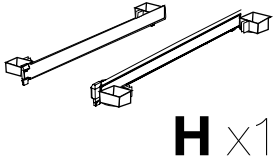

**1** Lay the top shelf of your Tuffy cart upside down and install the four legs intended for this shelf.

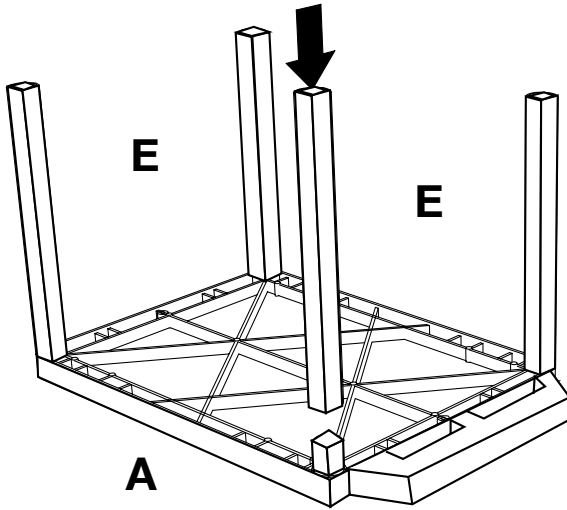

**2** Slide and align runner **H** & **G** onto the legs and tighten screw **N** with a screwdriver.

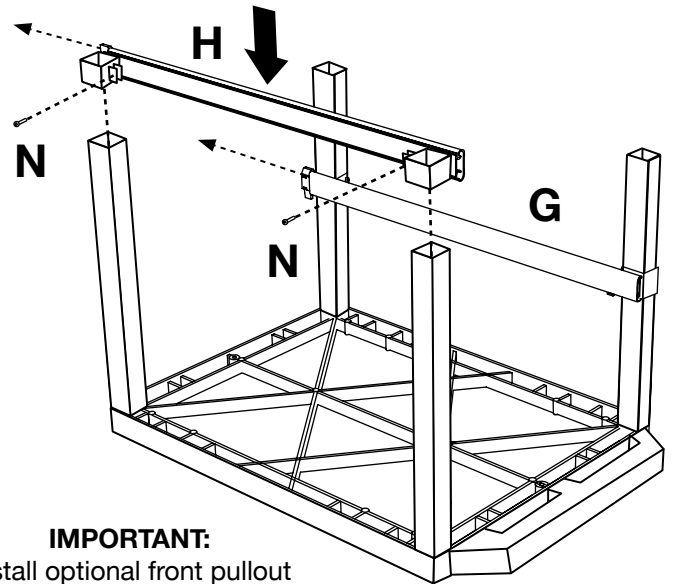

**IMPORTANT:**  
Install optional front pullout shelf **BEFORE** step 2

**3** Take pullout shelf **K** and bracket **L** and screw together into the unfinished surface of shelf **K** with screw **M**.

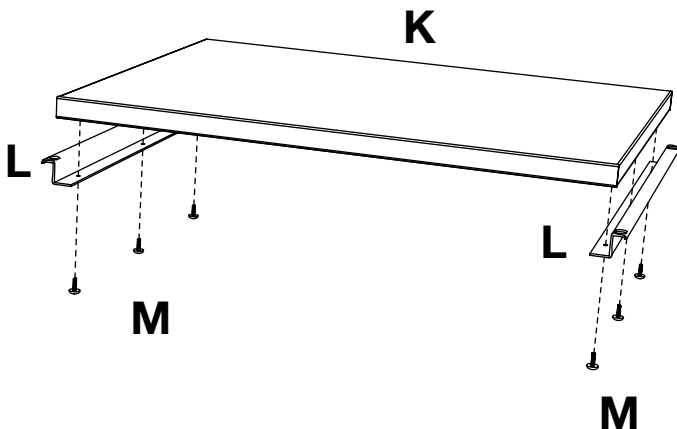

**4** Mount pullout shelf **K** to runner **H** & **G** so that the edge of the shelf snaps into the runner hooks.

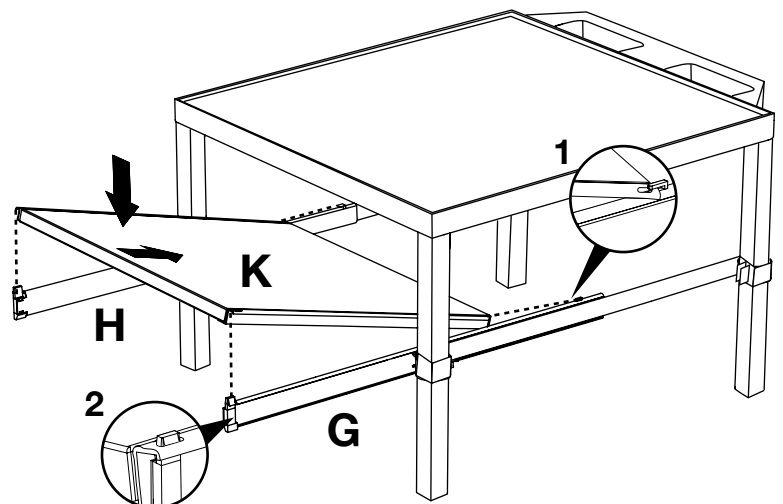

You have now completed your pullout shelf.